



Chemical Storage Tanks & Containment

FEATURING:
THE **ONLY** COVER
AND CONTAINMENT
OF ITS KIND!



Warrior Tanks
621 Pine Run Road, Suite B
Linden, PA 17744
570-916-3598

kristie@warriortanks.com

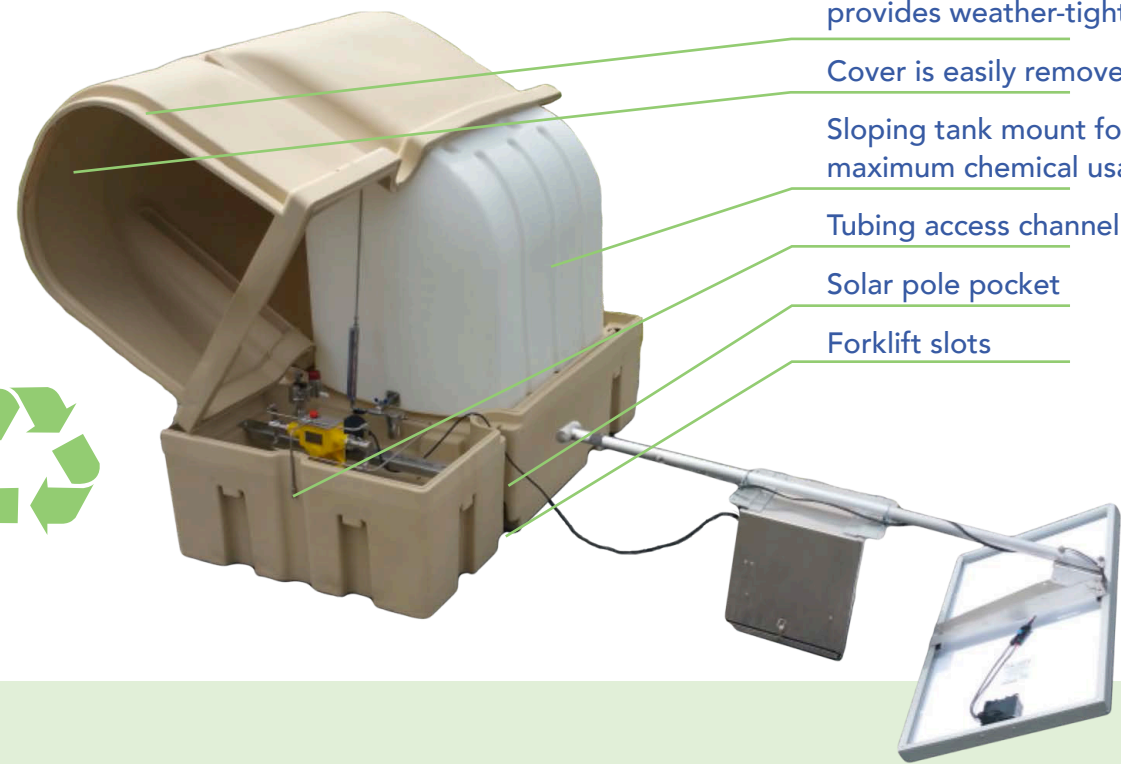

Rain gutter / door track provides weather-tight seal

Cover is easily removed

Sloping tank mount for maximum chemical usage

Tubing access channel

Solar pole pocket

Forklift slots

PRODUCT SPECS

- ① Weather resistant EPDM fasteners secure the weather-tight tongue & groove cover to the containment basin.
- ② Lightweight removable door featuring large, high-visibility viewing window with readily seen MSDS holder.
- ③ Simple design of snap-in solar pole does not require fasteners.
- ④ Enlarged pump pan with aluminum multi-functional mounting brackets.
- ⑤ Single, external cap for easy tank fill.

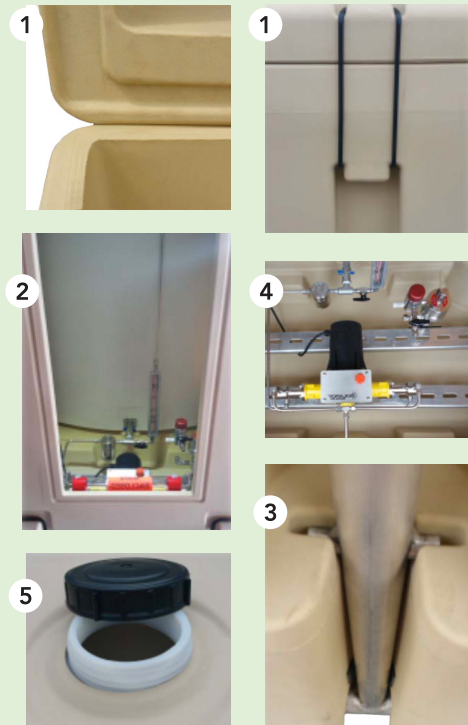

OTHER FEATURES

High density polyethylene construction.*

*Available in both HDPE and Crosslink construction.

Offered in several color options to match your company's preference.

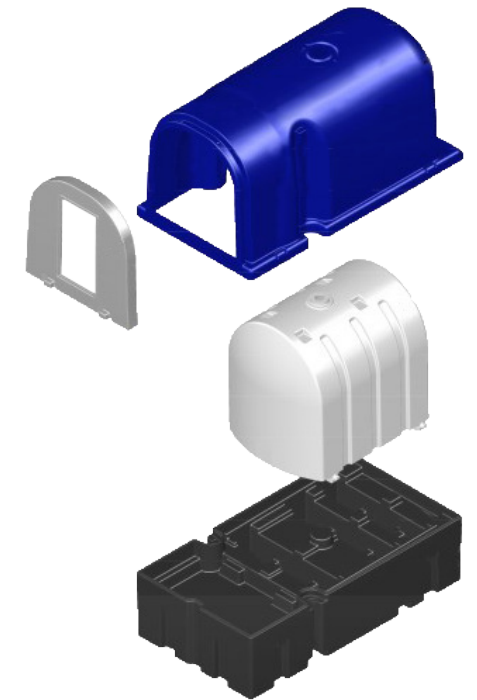

Overall Unit Dimensions
 L W H
 92" x 48" x 67.75"



SPILL CONTAINMENT CAPACITY
 110% of the tank capacity.



CHEMICAL TANK CAPACITY
 330 gallons plus 3% head space